

# Some things are just better split

## Rheem AmbiPower® Split Heat Pump

Built for tight spaces. High energy efficiency and powerful 5kW heating provides reliable hot water for the whole family.



COMES ON STEADY, HOT AND STRONG

INSTALL A



# WHERE POWER MEETS QUALITY IN A SPLIT HEAT PUMP SYSTEM

The AmbiPower® Split 5kW Heat Pump is a reliable, energy-efficient hot water solution that fits your home and lifestyle.

Designed to deliver powerful performance while helping you save on energy consumption, the AmbiPower® Split draws heat from ambient air to heat water for that perfect shower and all your hot water needs day and night.

## KEY BENEFITS

- **Up to 78% energy efficient<sup>3</sup>** With potential energy savings of up to 78% to heat your water as compared to a similar-sized electric water heater - it's a smart choice for reducing household energy consumption and carbon footprint
- **Fits where others can't** Ideal for homes with limited outdoor space – the tank can be installed indoors, like in a garage
- **Quiet comfort** Engineered for low-noise operation - keeping your home peaceful day and night
- **Fast and easy installation** Simple water connected split system - any certified plumber can install
- **Lower upfront costs** No need for specialist refrigeration installers - reducing installation expenses
- **Easy to maintain** Simplified access to both the unit and tank - makes regular maintenance a breeze
- **Safe and sealed** Factory-sealed refrigerant system - minimises the risk of leaks for long-term peace of mind
- **National Rheem Service Network** Rheem has a friendly service team nationally, which offers repairs under warranty. It can also offer expert maintenance, support, and advice to help your water heater run reliably for years to come

## HOW SPLIT HEAT PUMPS WORK



<sup>3</sup>Average Heating Capacity (kW): The average amount of heat added to water during the heating cycle, calculated at 19°C accounting for variations as water temperature rises.



**RHEEM ULTRANAMEL®**  
Exclusive coating, protects the cylinder against corrosion



**WORKS DAY & NIGHT**

Heat Pumps draw heat from the surrounding air to heat the water



**ENERGY EFFICIENT**  
Energy savings of up to 78%<sup>3</sup>



**POWERFUL ADVANTAGE**  
Rheem's Powerful Advantage\*



**TEMPERATE RANGE**  
Works in wide range of Aussie climates -7° to 43°

## ELIGIBLE FOR STCs

PLUS may be eligible for additional State Government rebates and incentives. See [rheem.com.au](http://rheem.com.au) for details.

COMES ON STEADY, HOT AND STRONG



## RHEEM AMBIPOWER® SPLIT 5kW



### FEATURES

- 4.6kW heating capacity at 19°C<sup>+</sup>
- High COP<sup>1</sup> – Coefficient of Performance of 4.5 @ 19°C<sup>+</sup>
- Provides faster water heating with a high efficiency compressor and double-walled heat exchanger
- Suitable for cold climates with an enhanced frost protection and an operating range from -7°C to 43°C
- Suitable for good water conditions<sup>2</sup>
- Energy savings of up to 78%<sup>3,+</sup>
- Smart controller and user-friendly touchscreen LED display controller on units
- Eligible for STCs (may be eligible for additional incentives in some states)
- 10 year cylinder warranty<sup>4,+</sup>
- Tank made by Rheem in Australia. Heater module developed and produced for Rheem Australia
- Available in 315L Vitreous Enamel Tanks (with Rheem Ultraname<sup>®</sup>) and Stainless Steel 325L tank capacity
- **Uses R290 refrigerant with a ULTRA LOW GWP of 0.02<sup>+</sup>**



### MODEL

### 565E315 & 565E32A

Storage capacity	Litres	315 VE & 325 SS
Boost capacity	L/hr	87
Rated Heat Pump power input	Watts	1.14
Heating capacity	kW	4.6
Recommended electrical circuit	Amps	7.3
Coefficient of Performance (COP) <sup>1</sup>		4.5
Recommended people per household <sup>6</sup>		Up to 6
Noise Level (LA90) @ 1 metre <sup>5</sup>	dB(A)	47

<sup>+</sup>Powerful advantage

TANK DIMENSIONS		565E315	565E32A
TANK	UNIT	VITREOUS ENAMEL	STAINLESS STEEL
CER Submitted		315	320
Nominal / Storage Capacity	litres	325	325
Tank Height	mm	1640	1760
Tank Width	mm	640	625
Tank Depth	mm	640	625
Tank Weight - Empty	kg	89	47
Tank weight - Cartoned	kg	96	53
Tank weight - Full	kg	414	372
TPR Valve Setting	kPa	1000	1000
Expansion Control Valve (ECV) Setting	kPa	850	850
Maximum Water Supply Pressure			
– With ECV	kPa	680	680
– Without ECV	kPa	800	800
Water connections		Rp 3/4	Rp 3/4

HEAT PUMP PERFORMANCE SPECIFICATIONS 565E315 & 565E32A				
Ambient air temperature	Relative Humidity	Average heating capacity (kW)	Recovery rate @ 45°C rise (L/hr)	Average Coefficient of Performance (COP) <sup>1</sup>
9.5°C	87%	3.7	70	3.8
19°C	65%	4.6	87	4.5
32°C	37%	5.4	102	4.6
33°C	58%	5.9	112	5.1

<sup>1</sup>This is the RATED POWER INPUT as specified in the AS/NZS 60335 test report. It is the maximum power the appliance will draw. <sup>2</sup>This is the RATED CURRENT as specified in the AS/NZS 60335 test report. It is the maximum current the appliance will draw.

AMBIPOWER® SPLIT 5kW		
MODEL	UNIT	
Energy Efficiency (Saving) <sup>3</sup>		78%
– @ Condition 2 ~ (19°C/15°C)		
Hot Water Heating Capacity		
– @ Condition 2 ~ (19°C/15°C)	kW	4.6
Coefficient of Performance (COP) <sup>1</sup>		
– @ ~ (19°C/15°C) (15-->60)		4.5
Hot Water Volume	L/h	87
Maximum or Rated Power Input (AS/NZS 60335) <sup>7</sup>	kW	1.75
Maximum Rated Current Input <sup>8</sup>	Amp	7.3
Power Supply	V/Ph/Hz	220V - 240V~/50Hz
Noise Level (LA90) @ 1 metre <sup>5</sup>	dB(A)	47
Default Outlet Set Temperature	°C	60
Maximum Outlet Water Temperature	°C	65
Operation Range	°C	-7 ~ 43
Defrosting		4-Way Valve
Refrigerant		R290
Cabinet		Steel
– Net Weight	kg	66
– Gross / Cartoned Weight	kg	78
Split Unit Dimensions & Weight		
– Net Dimensions (L/W/H)	mm	985 / 389 / 611
– Shipping Dimensions (L/W/H)	mm	1080 / 460 / 750

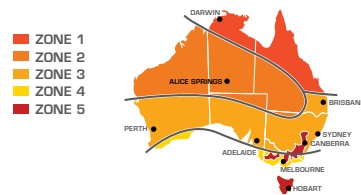
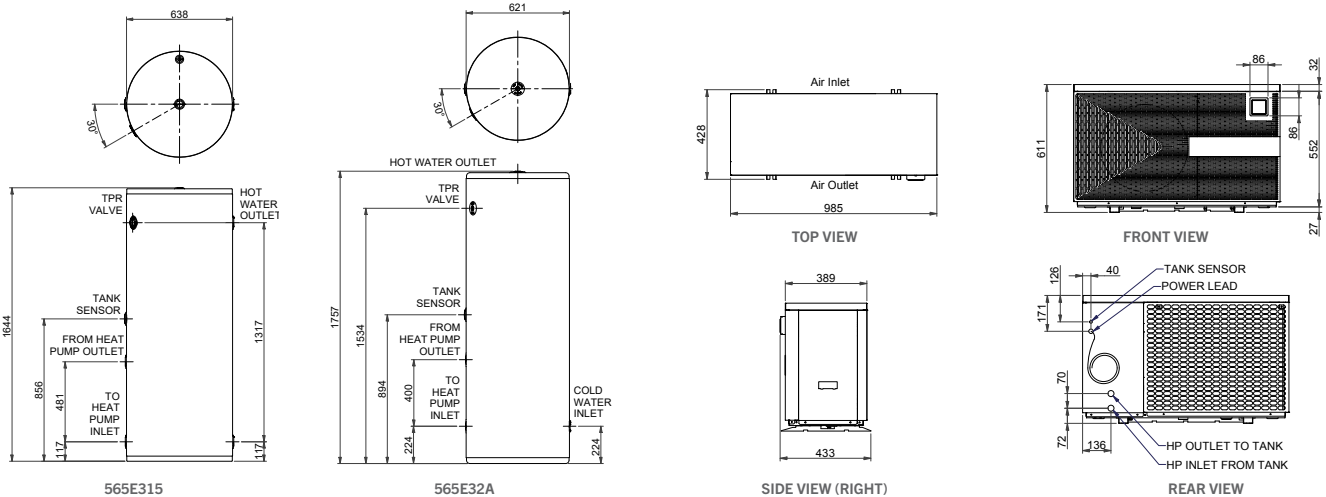

**STCs** Small-scale Technology Certificates (STCs) provide a financial incentive to encourage the installation of Solar and Heat Pump water heaters provided under a Federal Government legislated scheme.

This map shows the climate Zones within Australia which will define the number of STCs allocated to an approved Heat Pump water heater. The country is divided into climate zones for STC creation: 4 for solar and 5 for heat pumps.

For more information on STCs visit [www.rheem.com.au/rheem/help/offers-and-incentives/stcs](http://www.rheem.com.au/rheem/help/offers-and-incentives/stcs)

- The COP of 4.5 is the average value in the AS/NZS5125 performance test at 19°C ambient temperature over the entire heat-up process. Note that the actual COP of the product at any given time will be impacted by several factors, including the ambient and cold-water inlet temperatures at the place of installation and time of day/season of operation.
- Warranty limits regarding water chemistry. Harsh water regions – the Rheem warranty may not apply if the water heater is connected to a water supply which has a Total Dissolved Solids content >250mg/L; is scaling with a Saturation Index >+0.8, or is corrosive with a Saturation Index <-1.0.
- Energy savings of up to 78% is are based on operation at Condition #2 of AS/NZS 5125. Any savings will vary depending upon your location, type of water heater being replaced, hot water consumption and fuel tariff. Before installation - seek advice as to suitability to household usage and tariffs. The impact on an electricity account will depend on the tariff arrangement of the water heater being replaced and where you live. The water heater is recommended for connection to an uninterrupted 24 hour continuous tariff power supply. Depending upon the size of the household and its hot water requirements and if the Electricity Retailer permits, an extended off-peak (overnight and day) or Extended time controlled power supply connection of a minimum 16 hours per day may also be suitable. Before purchase consult your energy provider for more information on cost comparisons.
- Warranty Periods: 10 years supply on cylinder, 3 years labour on cylinder, 3 years supply on sealed system including labour, 1 year supply and labour on all other parts. Applies to a single-family domestic dwelling only. Conditions apply. See the Rheem warranty set out in the Owner's Guide and Installation Instructions or view at [www.rheem.com.au/warranty](http://www.rheem.com.au/warranty)
- Noise Level – A Noise Level (LA90) of 47 dB(A) was measured at 1m from the water heater during a Noise Test conducted to Standard GB/T 23137-2008 in a semi-anechoic chamber within a laboratory. The noise level when installed may be higher due to sound reflections from adjacent walls and structures.
- No. of people recommended based on 7 min showers @ 42°C. Appliances using hot water should be counted as one (1) person.



A Greater Degree of Good™ represents our global commitment to sustainability.



**Rheem Australia Pty Ltd.**  
 1 Alan Street, Rydalmere,  
 NSW 2116 Australia  
 PO Box 7508, Silverwater  
 NSW 2128 Australia  
[www.rheem.com.au](http://www.rheem.com.au)



RHE625-0072025-BELONG